

7620 & 7650 SOLID CINCHSEAL

Product Overview

The large-size industrial 7620 and 7650 solid, aluminum rotary shaft seals are designed for larger shaft sizes, ranging from 3.937" up to 6.00". They are ideal for screw conveyors, bucket elevators, and other bulk-handling equipment.

The 7620 model has a solid clear coat aluminum housing and end plate with solid hard coat anodized aluminum rotor cups and solid PTFE stator plates. The repair kits for the 7620 model are solid.

The 7650 model has a solid hard coat anodized aluminum housing and endplate but the internal parts of this model are split to make future repairs possible without having to unbolt the housing. Future repair kits will consist of split PTFE rotor cups and split elastomer.



FEATURES & BENEFITS

- » Designed for screw conveyors and other bulk-handling equipment, ranging from 3.937" to 6.00"
- » Temperature ranges -50°F to 400°F
- » Designed to accommodate repair kits
- » Bolting pattern will accommodate flange mounted bearings
- » The housing is machined out of Anodized Aluminum
- » Designed to handle linear shaft growth, and 1/4" total radial shaft runout
- » Purge with air, 5 to 8 psi above vessel pressure, or silicone grease
- » Zero maintenance due to unique self adjusting design

GARLOCK

Master Distributor for CinchSeal
Australia and New Zealand
2/198 Walters Road
Arndell Park NSW 2148 | Australia

Tel: +61 2 9793 2511
Fax: +61 2 9793 2544
www.garlock.com

7620 ASSEMBLY

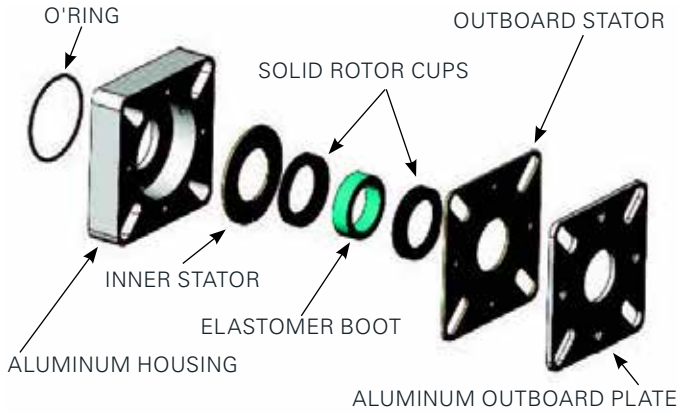

7650 ASSEMBLY

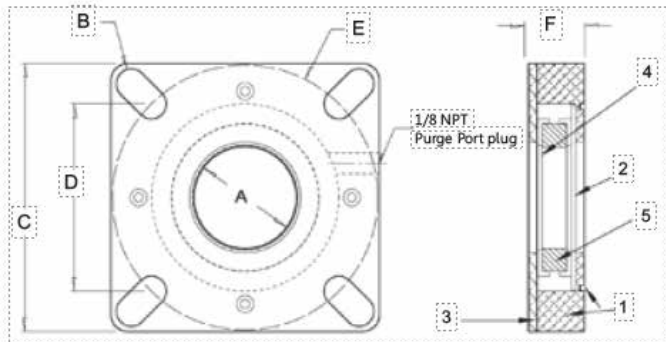
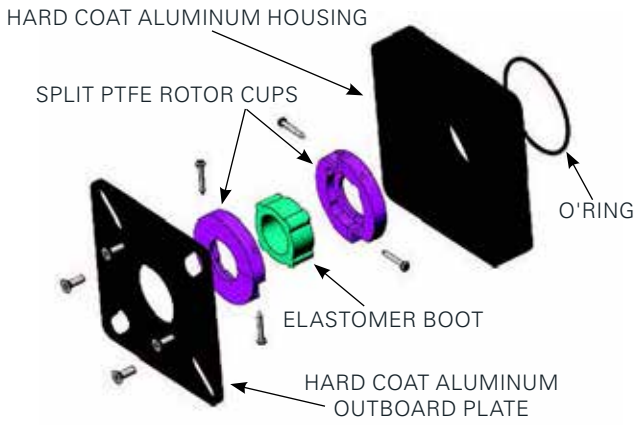

- 1. Housing - O'ring at Inboard
- 2. Inner Stator
- 3. Outboard Plate
- 4. Rotor Cup
- 5. Elastomer Boot - FDA Approved

DIMENSIONAL CHART

A	B	C	D MIN	D MAX	E MIN	E MAX	F
3.937	.810	10.00	6.125	8.852	8.662	12.518	1.75
4.437	.810	10.00	6.125	8.851	8.662	12.517	1.75

AVAILABLE ACCESSORIES

- » Seal Repair Kits
- » Air Pressure Regulators

HOW THE 7620 & 7650 SERIES WORKS

The key component in both industrial 7620 and 7650 rotary shaft seals is the blue elastomer that is molded out of an FDA-approved silicon material that is durable and can handle temperatures up to 400 F. The elastomer is molded slightly smaller than the shaft size so that an interference fit with the shaft is achieved. This snug fit seals the shaft and stops material from leaking out as well as causing the internal seal parts to turn with the shaft. Unlike mechanical packing and lip seals that are stationary and damage rotating shafts, our elastomer spins with the shaft thus eliminating any chance of shaft wear and damage. As the elastomer turns with the shaft, it drives two rotating faces - "rotor cups" that are compressed with optimum load against stationary faces to seal the potential leak paths. We offer both the 7620 model with solid internals and the 7650 model with split internals that is designed to be repaired with a split repair kit.

7620 MODEL

In the 7620 model, the internal sealing parts are solid and the seal must be unbolted and slide off an empty shaft to be rebuilt. The rotor cups are made out of aluminum that we then hard coat anodize to make the surface harder, and they turn against stationary faces - stator plates. This rotating face against a stationary face creates the primary seal. The PTFE stator plates are the sacrificial part of the seal and consist of a new solid elastomer and two new PTFE stator plates, and the seal is like brand new again.

7650 MODEL

In the 7650 model, the aluminum housing and end plate are solid but the internal sealing parts are split so that the seal can be repaired without having to unbolt the seal housing. This is the perfect scenario if you have a pillow block bearing arrangement and don't want to remove the bearing, gear box, or drive motor to rebuild the seal. The split "rotor cups" are made out of a mineral-filled PTFE, and they are now the sacrificial part of the seal. The 7650 repair kit consists of a new split elastomer and two split PTFE rotor cups.

The 7620 and 7650 are considered air-purged shaft seals that perform best when purged with continuous air pressure set at 5 to 8 PSI over internal vessel pressure. The air purge improves the seal life of the internal parts by creating a higher pressure inside the seal, which creates a natural air barrier that keeps product out of the seal and inside the equipment. Air also keeps the rotating seal faces cooler and adds closing force to the seal faces as they wear from use so product can't leak by.

Models 7620 and 7650 are available in shafts sizes, ranging from 3.937" up to 6.00" and are both repairable.

Confidential, U.S. Pat. No. 7,178,806. These drawings and specifications are the property of Garlock. Not to be released, or used for any manufacturing or sales without written permission. Other sizes and metric available.

CS-001_10.2021_AUST

GARLOCK

Master Distributor for CinchSeal
Australia and New Zealand
Tel: +61 2 9793 2511
Fax: +61 2 9793 2544
www.garlock.com

Industrial Gasket Solutions Ltd.

42 Hobill Avenue
Wiri, Auckland 2104
New Zealand
www.igs.co.nz
Tel: +64 9 574 5651
nzsales@igs.co.nz