

CEMA HEAVY-DUTY 7850 SANITARY SEAL

Product Overview

The maintenance-free CEMA heavyduty 7850 CinchSeal® for screw conveyors and other bulk-handling equipment are made from 316 stainless steel to handle dry and slurry products in the food service, pharmaceutical and chemical industries where stainless steel is a requirement. Why use antiquated technology like rope packing when CinchSeal® offers you a more efficient and greener alternative? Try CinchSeal® and stop powder and dust leaks in a Cinch!



FEATURES & BENEFITS

- » Designed for C.E.M.A. screw conveyor and bulk-handling equipment
- » Temperature ranges: -50° F to 400° F
- » Bolting pattern accommodates flangemounted bearings
- » Manufactured out of 316 stainless steel to handle caustic wash-downs
- » Designed to handle linear shaft growth and 1/4" total radial shaft runout
- » Purge with air, 5 to 8 psi above vessel pressure or silicone grease.
- » Zero maintenance due to unique selfadjusting design
- » Does not damage or undercut shaft. Stops product loss and premature bearing failure
- » Seals dust and vapors

GARLOCK

Master Distributor for CinchSeal
Australia and New Zealand
2/198 Walters Road
Arndell Park NSW 2148 | Australia

Tel: +61 2 9793 2511
Fax: +61 2 9793 2544
www.garlock.com

CEMA SS 7850 ASSEMBLY

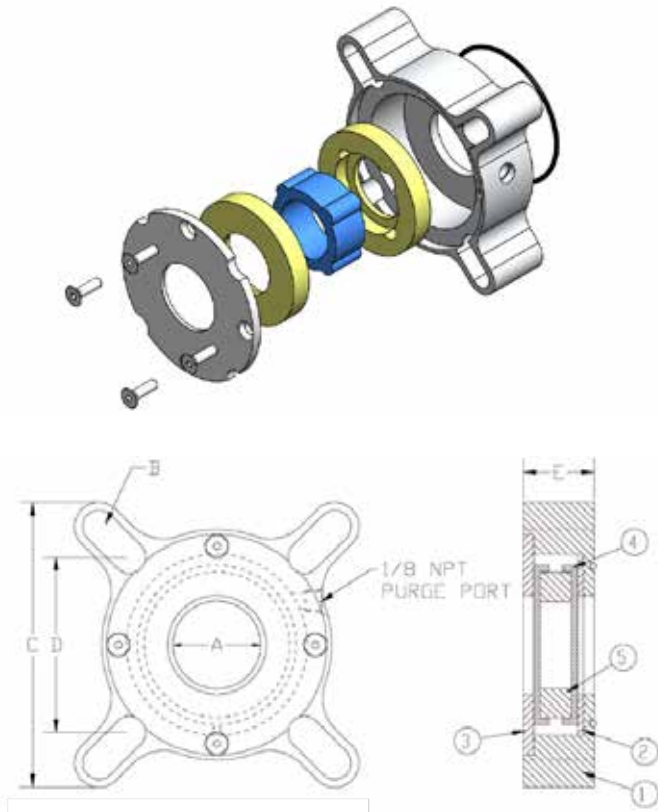

- 1. Housing - O'ring at Inboard
- 2. Inner Stator
- 3. Outboard Plate
- 4. Rotor Cup
- 5. Elastomer Boot - FDA Approved

DIMENSIONAL CHART

A	B	C	D MIN	D MAX	E MIN	E MAX	F
1.5	.625	5.375	3.30	4.375	4.667	6.187	1.75
2.0	.750	6.50	4.0	5.386	5.657	7.617	1.75
2.437	.750	7.375	4.5	6.26	6.364	8.853	1.75
3.0	.880	7.875	5.50	6.677	7.778	9.443	1.75
3.437	.880	9.25	6.76	8.052	9.560	11.387	1.75

Confidential, U.S. Pat. No. 7,178,806. These drawings and specifications are the property of Garlock. Not to be released, or used for any manufacturing or sales without written permission. Other sizes and metric available.

AVAILABLE ACCESSORIES

- » Seal Repair Kits
- » Air Pressure Regulators

HOW CEMA SS 7850 WORKS

The key component in the 7850 solid seal is the elastomer which is molded out of a special silicon material that can handle high temperatures. The elastomer is molded slightly smaller than the shaft size so that an interference fit is achieved. It is the interference fit of the elastomer and shaft that not only seals the shaft so product can't migrate past and leak out, but it also causes the internal seal parts to turn with the shaft so that damage to the shaft is eliminated. As the elastomer turns with the shaft it drives a pair of PTFE mineral filled rotor cups against two stationary faces to form the primary seal. The fact that CinchSeal turns with the shaft is what makes it unique and superior to rope packing and lip seals that are stationary and have the shaft turning through them which lead to scored shafts.

As the shaft turns, the elastomer drives two PTFE rotor cups that are being compressed with the optimum face pressure against a stationary face. It is the face pressure between the rotating faces and the stationary faces that stops material from leaking by. The PTFE rotor cups are the softer and sacrificial part of the seal, and are designed to wear and be replaced. Inexpensive re-build kits, which consist of a new elastomer and two new PTFE rotor cups, can be installed in minutes.

CinchSeal is an air purged seal that performs best when purged with 5 to 8 PSI of air over vessel pressure. The air purge improves seal life by accomplishing 3 things: it creates a higher pressure inside the seal which creates a natural air barrier that helps keep material out of the seal. Keeps the rotating faces cooler, and it adds to the closing force on the seal faces so product can't leak by.

The 7850 seal meets all C.E.M.A. dimensions and is easy to bolt up in place of waste packs, plate seals, and packing glands. Try CinchSeal today and stop all powder and dust leaks on all your rotating equipment.

SELF ADJUSTMENT AND ALIGNING

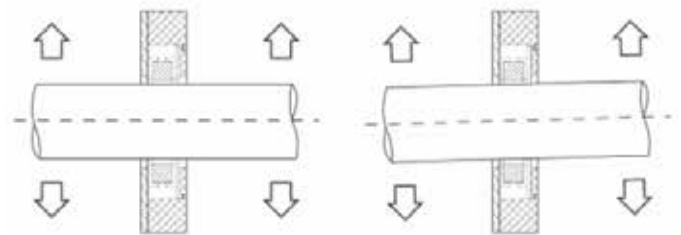

The CinchSeal module readily accommodates a reasonable amount of shaft vibration, misalignment or wobble. The rotor cup "floats" against the face of the stator plate so any lateral shaft movement produces nothing more than a slight orbital eccentricity.

CS-002_10.2021_AUST

GARLOCK

Master Distributor for CinchSeal
Australia and New Zealand
Tel: +61 2 9793 2511
Fax: +61 2 9793 2544
www.garlock.com

Industrial Gasket Solutions Ltd.

42 Hobill Avenue
Wiri, Auckland 2104
New Zealand
www.igs.co.nz
Tel: +64 9 574 5651
nzsales@igs.co.nz